

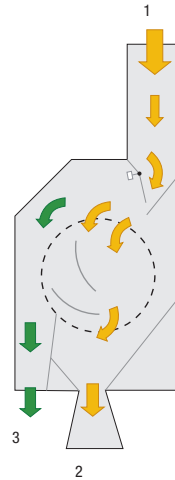

Drum Cleaner without Aspiration System

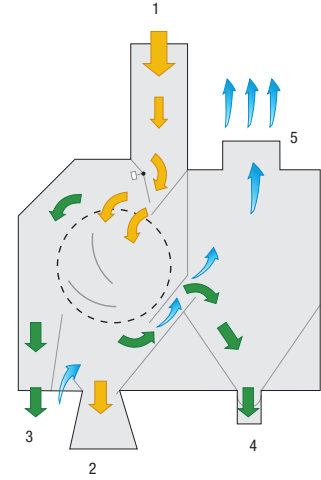

Drum Cleaner with Aspiration System



- 1 - Inlet hopper
- 2 - Cleaned product
- 3 - Outlet of the large product
- 4 - Outlet of the small product
- 5 - Connection pipe for Ventilator and Cyclone for waste air

The **PETKUS Rotary Drum Cleaners SD 10 / SD 15** are designed for the pre-cleaning of free flowing granular products such as grain, oilseeds and pulses.

Rotary Drum Cleaners are mainly used in the intake area of plants as separators for coarse particles (stones, clods of earth etc.).

#### Advantages:

- Highly suitable for the cleaning of products which are in damp or soiled condition
- High throughput performance
- Relief of the following cleaners and dryers
- Reliable and low-maintenance

#### Description:

The product is transported into the machine through the weight-controlled inlet flap. This enables a uniform distribution and an optimal product flow, even when the throughput or product changes. The product flows through a rotating screen drum. Coarse rejects are separated and discharged here on the periphery of the screen drum.

The model with aspiration additionally cleans the product with an airflow. Dust and light rejects are separated, and are moved into the depositing chamber. From there they are discharged over an extraction auger.

The screened product is discharged over an outlet hopper.

#### Construction:

The Rotary Drum Cleaners consist of an inlet with a weight-controlled flap and a screen drum. The model with the aspiration is additionally equipped with a depositing chamber with an extraction auger as well as a fan.

The various components of the machine (screen drum, fan, discharge auger) are operated by electric motors.

#### Standard Equipment:

- Bolted frame made of galvanized sheet steel
- Screen drum with the perforation 25 mm x 50 mm for pulses and corn or with the perforation 25 mm x 25 mm for cereals
- Aspiration
- Drive unit with electric motor

#### Standard Equipment:

- Without aspiration
- Discharge left



Screen drum

# Rotary Drum Cleaners SD 10 / SD 15

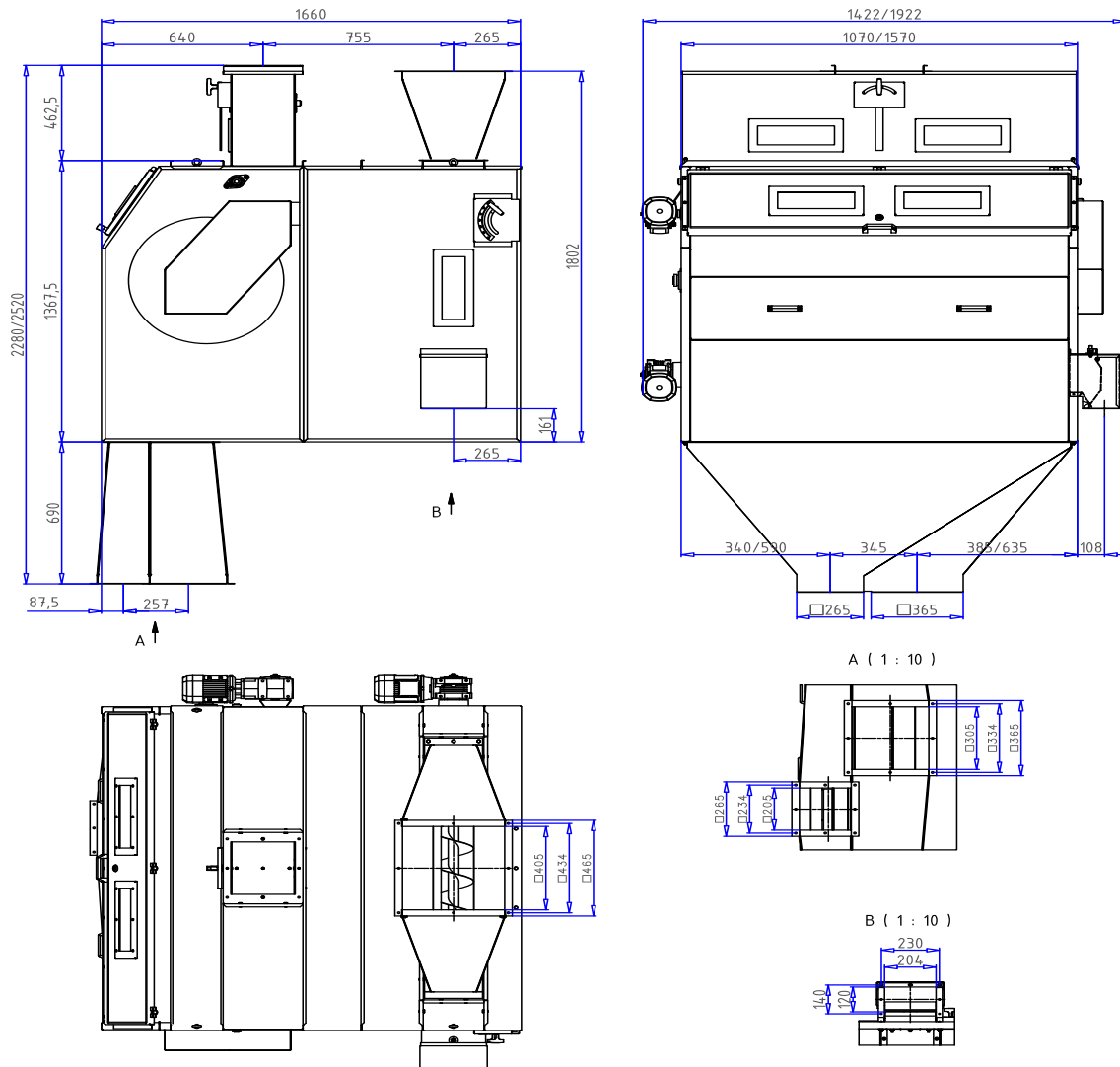

Technical Data		SD 10	SD 15
Capacity for cleaning maize/corn	bu/hr	1 800	2 700
Capacity for cleaning wheat	bu/hr	2 500	3 600
Length, L	in	65.5	65.5
Width, B	in	56	75.75
Height, H	in	89.75	99.25
Motor for:			
- Discharge screw (only TSR-A)	hp	0.5	0.5
- Screen drum	hp	0.74	0.74
- Inlet valve	hp		
- Fan for aspiration	hp	5.5 - 7.5	7.5 - 15.0
Weight machine	lb	1 300.7	1 554
Weight with grain	lb	1 565	1 940

Technical alteration reserved.