

# Seed Cleaner Type K 06



The **PETKUS Seed Cleaner K 06** is used for high-quality seed cleaning of free flowing bulky products, e.g. pulses which do not need to be processed with an indented cylinder. Furthermore, the seed cleaner can also be used for the intensive cleaning of grain and oilseeds. The high standard of cleaning is achieved by a combination of the screening system and the air aspiration.

## Advantages:

- Suitable for various products due to extensive setting options
- High standard of cleaning
- Simple and quick changing of screens
- Two different air volume ranges adjustable for various products
- Highly effective cleaning of the screen surfaces by screen agitators (top screen) and brushes (bottom screen)

## Description:

The product is moved from the inlet hopper through the pre-aspiration duct. Light rejects, husk and dust are separated here. Afterwards, the product is transported to the screen compartment. The top screen separates large and coarse rejects. The top screen is cleaned with a screen agitator. Light rejects are separated by the bottom screen. A brush carriage cleans the bottom screen. The screened product is transported through the final aspiration duct. Further light rejects with lower density are separated there by the air flow. The cleaned products are transported to the discharge and can be bagged-off there.

## Construction:

The Seed Cleaner K 06 is equipped with an inlet hopper, one pre- and final aspiration duct with depositing chambers, a screen compartment with two screen layers. The various components of the machine (inlet hopper, screen compartments, fan etc.) are operated by a V-belt system with an electric motor.

## Standard Equipment:

- Bolted frame made of painted sheet steel
- Set of screens for screening diagram
- Screen agitators and brush carriage
- Drive unit with 3.0 kW electric motor

## Options:

- Screens available for a large number of different products

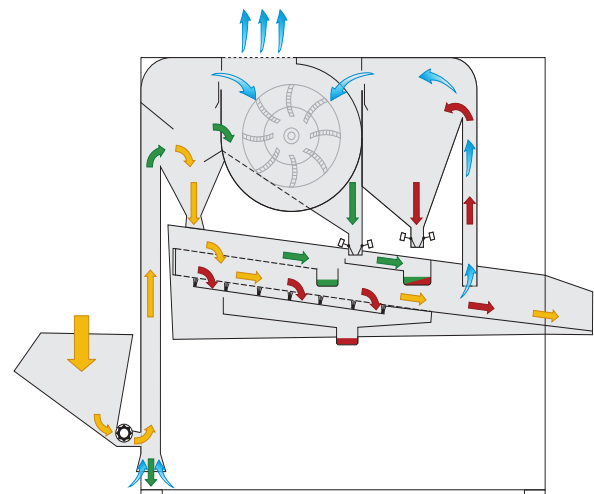

Working principle Seed Cleaner Type K 06

# Seed Cleaner Type K 06

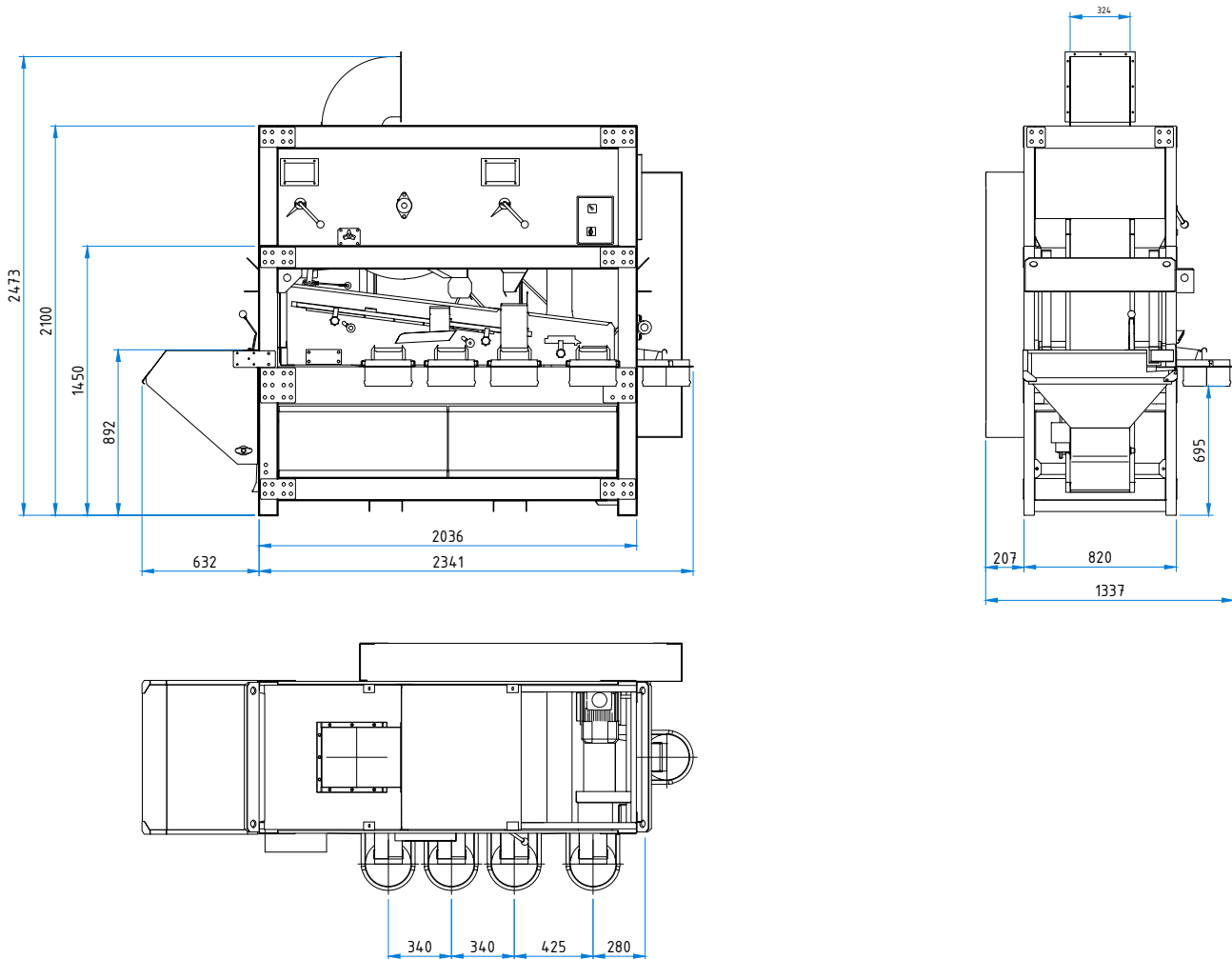

Technical Data		K 06
Capacity (Based on: Wheat)		
Industrial cleaning	bu/hr	65
Seed cleaning	bu/hr	45
Working width	in	25
Screen area	in <sup>2</sup>	13.45
Air volume 1	cfm	2650.5
Air volume 2	cfm	3416.2
Drive motor	hp	4.0
Speed	rpm	1 450
Speed of the fan 1	rpm	900
Speed of the fan 2	rpm	1 100
Weight	lb	ca. 2 028

Technical Data		K 06
No. of Screen layers	pcs.	2
Upper screen layer	pc.	1
Lower screen layer	pc.	1
Cleaning of upper screen layer		Agitators
Cleaning of lower screen layer		Brushes
Dimension		
Length	in	114.75
Width	in	52.75
Height	in	82.75
Total height with pipe connection	in	97.5
Air exhaust system		
Diameter pipe for exhaust system	in	17.75
Cyclon type	FKA	1 250/1 600

Technical alteration reserved.